

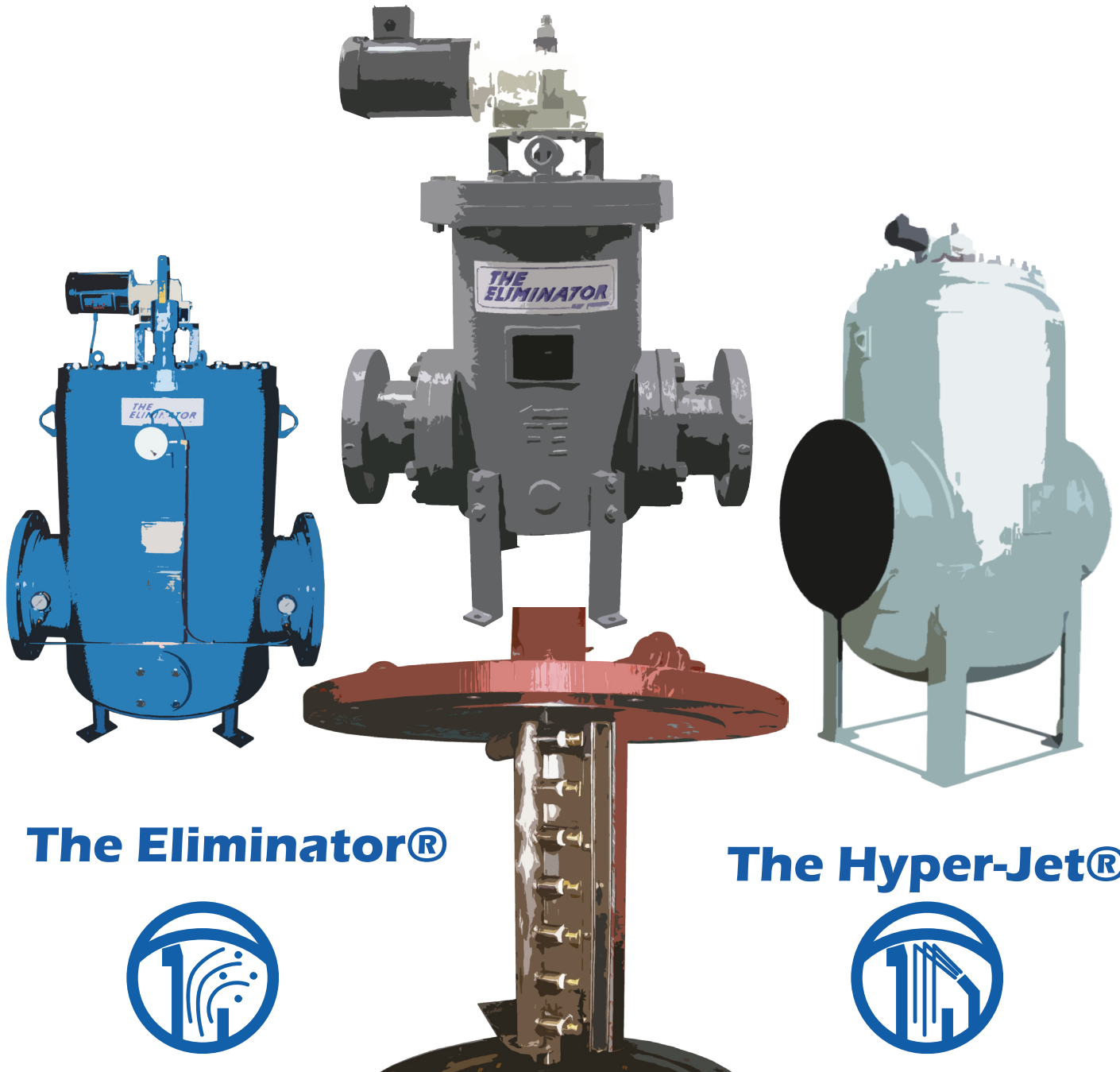

SC INDUSTRIAL SALES

Phone: 603-577-8707 - sales@scindustrialsales.com -
www.scindustrialsales.com

**Automatic Self-Cleaning
Strainer/Filter Systems**



The Eliminator®



The Hyper-Jet®



"Engineered Products for Demanding Applications, Performance, and Service"

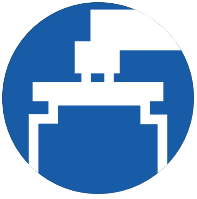

The Eliminator®

Model 723/723T/753/793

The Eliminators®, motorized, automatic, self-cleaning strainers by Fluid Engineering, provide continuous debris removal from fluid piping systems that demand full time uninterrupted flow.

The Eliminators® are particularly effective in fluid applications where unattended service, high solids loading and/or uninterrupted flow requirements deem a basket strainer and its attendant maintenance problems impractical.

Any of the Fluid Engineering 700 Series Strainers, applied correctly, will prove efficient and cost effective compared to simplex/duplex strainers or other automatic straining systems.

PROVEN FEATURES INCLUDE

- Patented rugged screen and mechanical assist backwash mechanism extends useful service life.
- Unique clog-resistant straining element reduces maintenance downtime.
- Unique adjustable accelerator plate aids cleaning in difficult applications.
- All internal replacement parts supplied in corrosion resistant material.
- Efficient proven design reduces maintenance requirements; requires fewer parts.
- Flats for manual operation in case of power failure.
- Low rpm backwash mechanism provides more efficient cleaning, less wear of internals.



APPLICATION

The Eliminator's® patented unique strainer element design permits installation in virtually any piping system operating at a positive pressure.

The Eliminators® can operate through a wide range of operating pressures (10 psig minimum) and solids loading with effective debris removal and backwashing across the entire pressure range. Additionally, only one drain/backwash connection is required for installation effectively eliminating the expense of a separate backwash connection.

Strainers are used to protect equipment such as valves, pumps, meters, heat exchangers, or spray nozzles, as well as in feed water and process water applications or virtually any similar application.

The Eliminator® 700 Series Automatic Self-Cleaning Strainers are fabricated in pipe sizes ranging from 1" to 48" to suit most application requirements.

How the 700 Series Eliminator® works

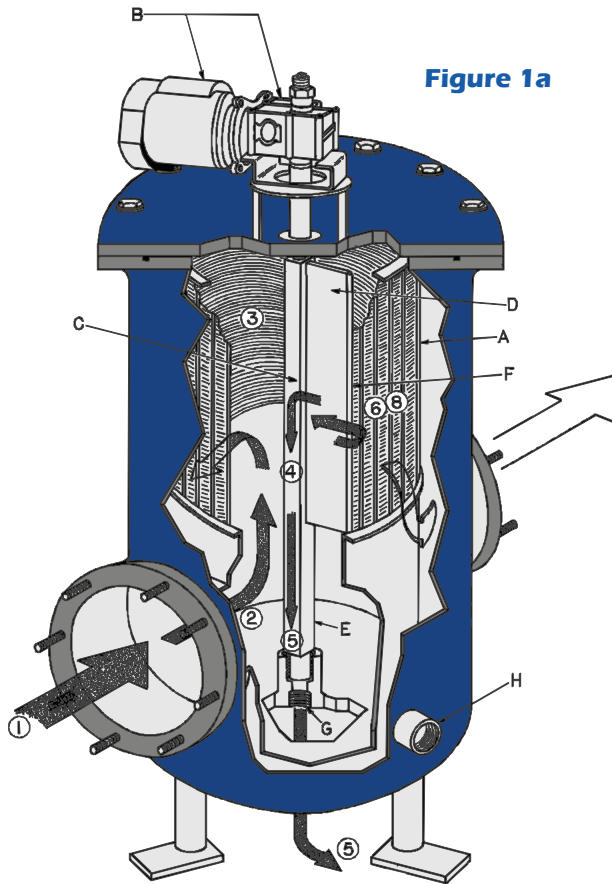

Figure 1a

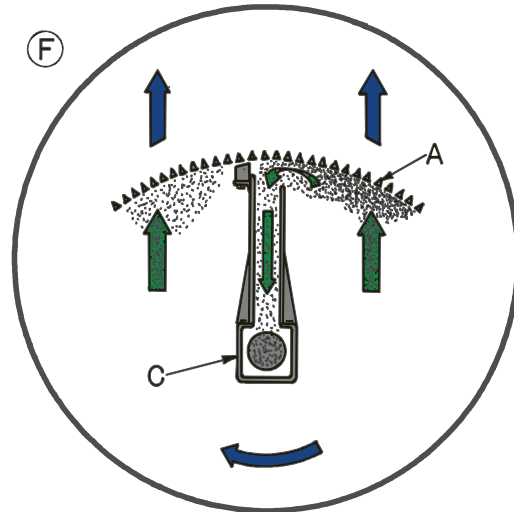

Figure 1b

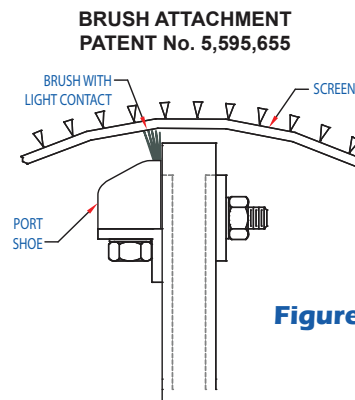
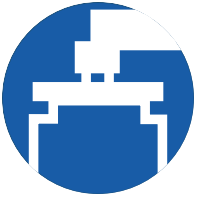

Figure 1c

1. Debris laden fluid enters through inlet to inner chamber (Figure 1a).
2. Dirty fluid flows upward to the strainer element (A).
3. Debris is retained on the flat face of the strainer element, while stained fluid continues to outer chamber and exits through strainer outlet (See Figure 1a).
4. During backwash or cleaning cycle, the motor/gear reducer (B) is engaged and drives the hollow drive shaft (C) and hollow port (D) around the inner circumference of the strainer element.
5. The backwash assembly C, D, and E are opened to atmospheric pressure by opening the backwash control valve (not shown).
6. Flow reversal occurs at the port/straining element (F) interface because of the pressure differential described in 5 (See Figure 1b).
7. Debris is effectively vacuumed from the full length of the straining element by a vigorous reverse fluid flow and into the hollow port; down the hollow drive shaft and out the backwash outlet (G).
8. The hollow port continues to sweep the full length of the strainer element until the cleaning cycle has ended.
9. A brush molded to the port shoe facilitates debris removal on the straining element (See Figure 1c). A non-brush port shoe is available as an option.
10. The strainer will provide continuous uninterrupted fluid flow during the cleaning operation.
11. The cleaning cycle can be set for continuous or intermittent backwash.

U.S. Patent No. 4,818,402
Canadian Patent No. 1,314,235



The Hyper-Jet®

Model 721/751

The Hyper-Jet® is Fluid Engineering's additional line of motorized, automatic self-cleaning strainers. On fluid piping systems, which demand added cleaning abilities due to application requirements, the Hyper-Jet® provides continuous uninterrupted debris removal.

The Hyper-Jet® is very effective in system applications where operating pressure is low (under 5 psig) or where the system debris has particularly difficult removal characteristics. Fluid Engineering's 721/751 Series strainer provides unattended service with the addition of external backwash fluid that enhances the self-cleaning attribute over other automatic strainers.

APPLICATION

The Hyper-Jet's® unique patented backwash system coupled with Fluid Engineering's strainer element design permits installation in a broader range of system applications. This scope of operations includes from relatively low pressure to very high pressure and from withdrawing coarse, easily removed debris to fine, sticky debris.

In a low pressure mode (such as on the suction side of a pumping system), the Hyper-Jet® system is mounted on the leading edge of the strainer backwash arm (Fig. 2). External fluid is directed at an incident angle over the inside surface of the straining element through the high-pressure nozzle assembly. The high velocity of this spray assists the cleaning of the wedge-wire straining element. External source pressure must be a minimum of 30 psi over system operating pressure.

Hyper-Jet® strainers are used to protect equipment such as pumps, motors, heat exchangers, or spray nozzles, as well as process applications such as cooling towers or virtually any similar application.

The Series 721/751 Hyper-Jet® Self-Cleaning Strainers are fabricated in pipe sizes ranging from 1" to 36" to suit most application requirements. The Hyper-Jet® System can also easily and economically be field installed in any Fluid Engineering Self-Cleaning Strainer (6" size and larger) in service as a retrofit installation.

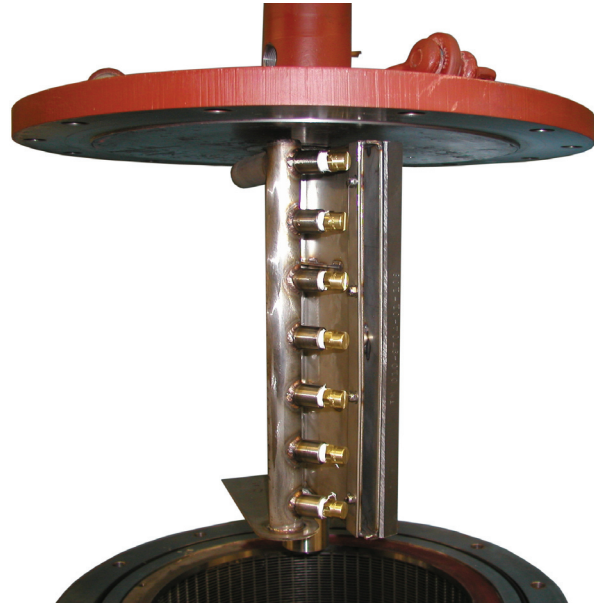

Figure 2 - The Innovative Internals of the Hyper-Jet®

PROVEN FEATURES INCLUDE

- A unique patented spray assisted/ mechanical backwash mechanism for extended service life.
- A clog-resistant straining element (wedge-wire configuration) to reduce maintenance downtime and operator assisted attention.
- All internal replacement parts supplied in corrosion resistant materials (special material available on request).
- An efficient, effective cleaning mechanism which reduces annual maintenance, requiring fewer parts.
- A low rpm backwash cycle provides more efficient cleaning, less wear (no contact between rotating parts) and longer duty cycle on motors and speed reducers.
- Any existing Eliminator® (6" and up) can be converted to the Hyper-Jet®.

How the 700 Series Hyper-Jet® Works

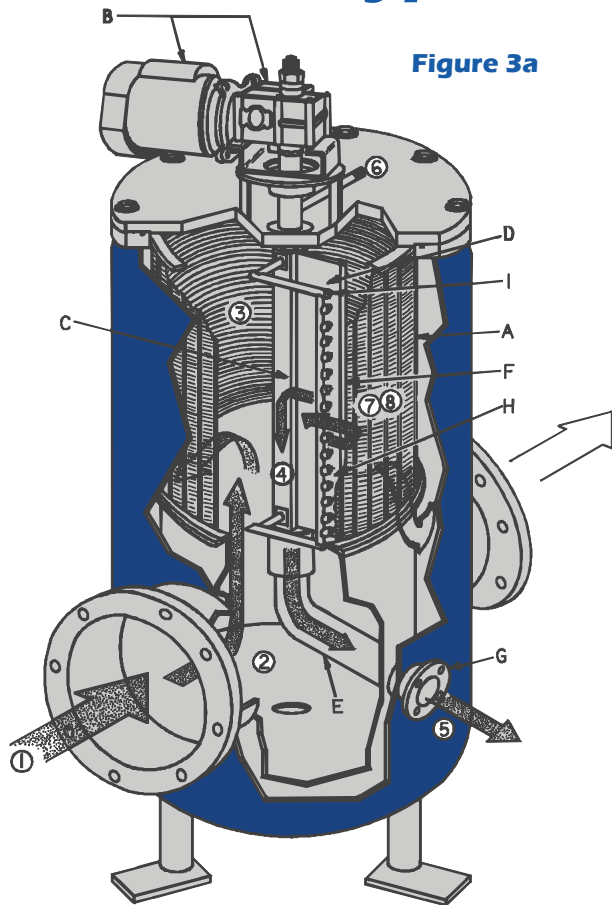

Figure 3a

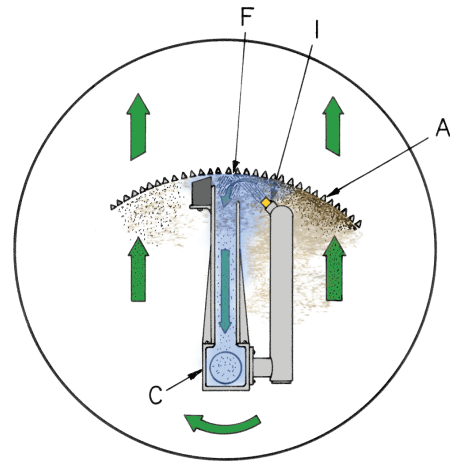

Figure 3b

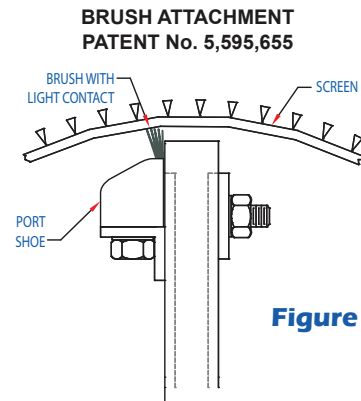

Figure 3c

1. Debris laden fluid enters through inlet to inner chamber (Figure 3a).
2. Dirty fluid flows upward to the strainer element (A).
3. Debris is retained on the flat face of the strainer element, while strained fluid continues to outer chamber and exits through strainer outlet (See Figure 3a).
4. During backwash or cleaning cycle, the motor/gear reducer (B) is engaged and drives the hollow drive shaft (C) and hollow port (D) around the inner circumference of the strainer element.
5. The backwash assembly (C), (D), and (E) are opened to atmospheric pressure by opening the backwash control valve (Not shown).
6. The external source of fluid is introduced by opening the control valve (Not shown) connecting the spray nozzles (J) at the leading edge (F) of the backwash assembly.
7. A "Jet" spray action occurs at the straining element inside surface (See Figure 3b) in addition to the flow reversal at the port/straining element inter-face (H).
8. Debris is effectively removed from the full length of the straining element by a vigorous Hyper-Jet® fluid flow into the hollow port; down the hollow drive shaft and out the backwash outlet (G).
9. A brush molded to the port shoe facilitates debris removal on the straining element (See Figure 3c). A non-brush port shoe is available as an option.
10. The hollow port continues to sweep the strainer element until the cleaning cycle has ended.
11. The strainer will provide continuous uninterrupted fluid flow during the cleaning operation.
12. The cleaning cycle can be set for continuous or intermittent backwash.

US Patent No. 5,152,891

Straining Element

The Eliminator® features a revolutionary reverse rolled wedge-wire straining element (Figure. 4) that is extremely rugged and more clog resistant than conventional strainer elements that use perforated plate or wire mesh screens.

This proven state-of-the-art straining media is fabricated by wrapping vertical rods with wedge shaped profile wire. Each intersection of rod and wire is welded to produce an extremely rugged one-piece element. This forms a continuous slot that allows only two-point contact with debris particles to reduce clogging.

The wedge shaped profile wire reduces the possibility of retaining debris smaller than the screen opening which historically has been the cause of premature clogging or failure of competitive screen designs.

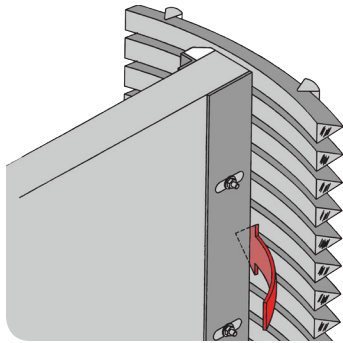

Figure 4 - Wedge Wire Straining Element Cross-Section with Adjustable Accelerator Plate

ADVANTAGES OF WEDGE WIRE STRAINING ELEMENT

- Maximum effective flow area and maximum operating efficiency are maintained throughout service life.
- Maintenance costs are reduced drastically due to reduced clogging and stapling of fibrous material.
- Long-lived straining element provides reduced operating costs over entire service life.
- Rigid element prevents flexing which can cause premature element failure.
- Efficient, effective debris collection at media/screen interface.

STANDARD SCREEN MATERIALS

- 304 Stainless Steel
- 316L Stainless Steel
- Monel
- Other materials available upon request

Figure 5 - Wedge Wire Straining Elements



Figure 6 - Optional Perforated Straining Element



STRAINING ELEMENT SELECTION

The 700 Series Straining Element (Fig. 5 & 6) is an extremely rugged, single-piece unit available in a variety of standard and custom openings and materials.

Screen opening should be selected based on the amount of protection necessary and not on the smallest opening available. By specifying a smaller opening than needed, more debris will be retained and will subsequently result in longer cleaning durations and increased backwash fluid loss. Also, smaller than necessary screen openings will reduce open screen area and increase pressure loss.

The screen opening should be sized approximately one third (1/3) to one half (1/2) the largest size particle that can safely pass downstream. Example: A strainer protecting spray nozzles with a 1/16" orifice should be supplied with a 1/32" screen opening.

Slot Opening (inches)	Fraction Equivalent (inches) (mm)	Mesh Equivalent	Micron Equivalent	% Open Area
Standard				
0.003	(0.08)	200	76	9
0.006	(0.15)	100	152	16.5
0.010	(0.25)	50	254	17.5
0.015	1/64 (0.4)	40	381	24
0.020	(0.5)	35	508	30
0.032	1/32 (0.8)	20	813	40
0.062	1/16 (1.6)	10	1575	51
0.125	1/8 (3.2)	6	3175	67
0.187	3/16 (4.8)	4	4750	72
0.250	1/4 (6.4)	3	6350	78
Other slot openings are available upon request.				

Typical Strainer Specifications

The strainer shall be Series 723/793 Self-Cleaning, motorized type, as designed and manufactured by Fluid Engineering, Erie, PA.

The body and cover shall be fabricated (carbon steel) designed, manufactured and tested generally to ASME Section VIII standards, using qualified ASME Section IX welders.

Housing to be suitable for a design pressure of 150 psig. Inlet and outlet connections shall be flanged and conform to ANSI B16.5 standards. The strainer shall have a single backwash connection and drain blowoff connection. Strainer to be complete with factory supplied steel support legs for bolting to concrete or steel base.

Strainer shall be _____ size capable of handling _____ gpm of fluid at a _____ psig pressure loss with clean straining element.

The straining element will be manufactured from corrosion resistant (304 stainless steel) reverse rolled slotted wedge wire screen designed with _____ inch openings. The wide or flat cross section of the wedge wire shall face the direction of flow providing for a continuous smooth flat surface to trap debris. The straining media shall be free of pockets, tubes, collector bars, etc. that accumulate and trap debris permanently.

All internal parts will be corrosion resistant (stainless steel). The strainer shall be provided with drive shaft and hollow port assembly fitted with all necessary bearings and seals.

The drive arm and hollow port assembly including

the adjustable accelerator plate will be free running at a maximum speed of two (2) rpm and will not contact the screen surface. Port assembly shall be factory and field adjustable for positive effective cleaning and shear capability.

NOTE: Sizes 1" thru 16" have (1) backwash hollow port. Sizes 18" and up will have (2) backwash hollow ports.

Drive shaft will be supported at the top with roller bearings located in a double reduction gear reducer and at the bottom with a water lubricated guide bearing.

The gear reducer shall be driven by a _____ hp, _____ V, _____ Ph, 50/60 Hz, TEFC motor.

STRAINER OPTIONS AVAILABLE

- Cover Lift: Assemblies: Recommended for remote locations.
- ASME: ASME Section VIII, Division 1. 10 CFR 50 Appendix B. ASME Section II, Class 3.
- Materials of Construction: Consult factory for stainless steel, copper nickel, monel, or other requirements.
- Control Package: Control Panel, Backwash Valve with electric operator, single element differential pressure switch.
- Design: High-pressure applications, please consult the factory.
- Hyper-Jet: Low pressure and special applications.
- Skid packages: All equipment desired, including strainers, valves, controls, wiring, piping, and skids may be combined as a complete, custom package. Size of the project has no limitation.

Pressure Drops Charts

MODEL 721/723

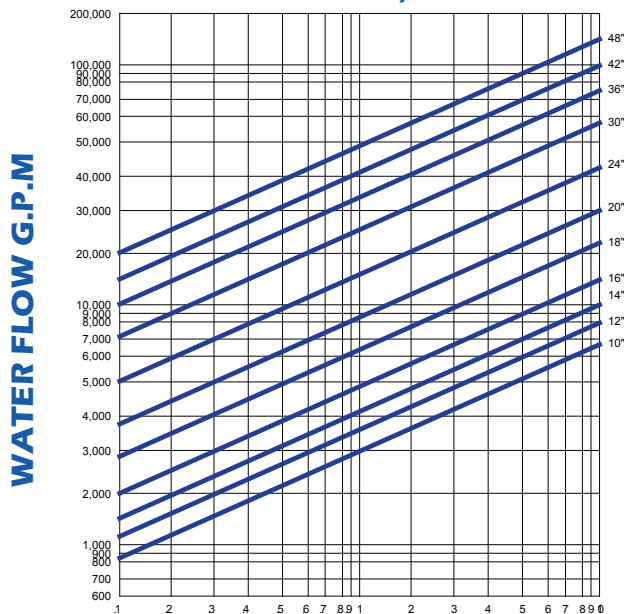

MODEL 721/793

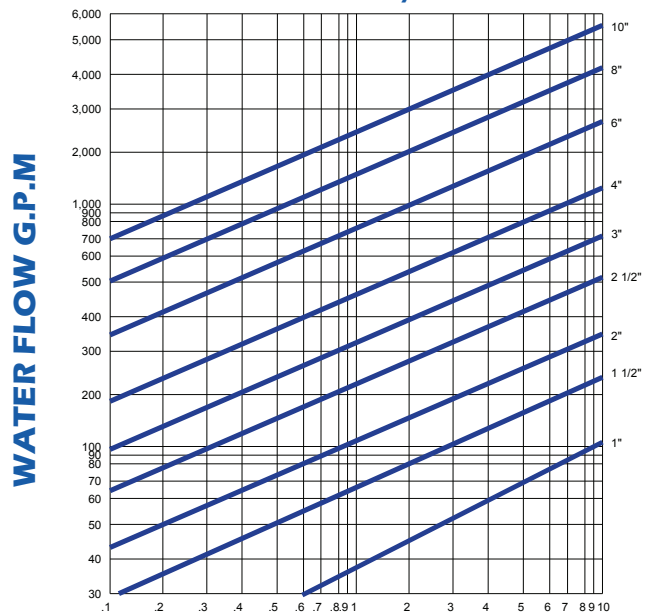

PRESSURE DROP P.S.I. WITH 1/32" OR LARGER SCREEN OPENING

Specifications Dimensions/Weight

MODEL 721/793 1" - 10"

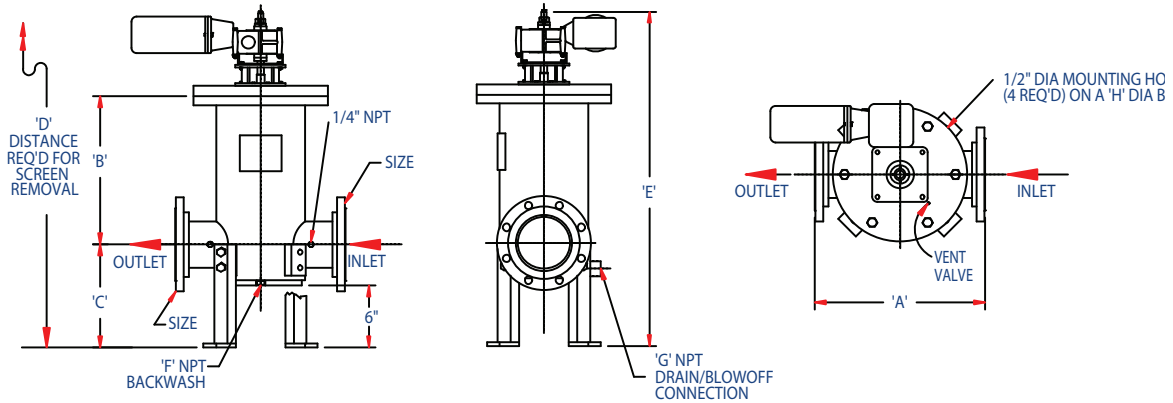

Model No.	Size (in.)	A (in.)	B (in.)	C (in.)	D* (in.)	E* (in.)	F (in.)	G (in.)	H (in.)	Dry Lbs	Wet Lbs	Lbs Cov.	Motor H.P.
010-793	1-150	16 ¹ / ₂	14 ¹ / ₄	10	59	36 ¹ / ₂	1 NPT	1 NPT	11 ⁷ / ₈	295	440	130	1/4
015-793	1 ¹ / ₂ -150	16 ¹ / ₂	14 ¹ / ₄	10	59	36 ¹ / ₂	1 NPT	1 NPT	11 ⁷ / ₈	300	445	130	1/4
020-793	2-150	16 ¹ / ₂	14 ¹ / ₄	10	59	36 ¹ / ₂	1 NPT	1 NPT	11 ⁷ / ₈	305	450	130	1/4
025-793	2 ¹ / ₂ -150	16 ¹ / ₂	14 ¹ / ₄	10	59	36 ¹ / ₂	1 NPT	1 NPT	11 ⁷ / ₈	310	455	130	1/4
030-793	3-150	16 ¹ / ₂	14 ¹ / ₄	10	59	36 ¹ / ₂	1 NPT	1 NPT	11 ⁷ / ₈	315	460	130	1/4
040-793	4-150	16 ¹ / ₂	14 ¹ / ₄	10	59	36 ¹ / ₂	1 NPT	1 NPT	11 ⁷ / ₈	325	470	130	1/4
060-721/793	6-150	20	15 ⁵ / ₈	11	65	38	1 ¹ / ₂ NPT	1 NPT	16	560	750	170	1/4
080-721/793	8-150	28	18	16	74	46 ¹ / ₂	1 ¹ / ₂ NPT	1 NPT	21 ¹ / ₄	825	1065	180	1/4
100-721/793	10-150	28	18	16	74	46 ¹ / ₂	1 ¹ / ₂ NPT	1 NPT	21 ¹ / ₄	840	1080	180	1/4

(*) Add 5¹/₄" for Model 721. Threaded (NPT) Inlet/Outlet Connections are available. Weights are approximate.

MODEL 721/723/723T 10" - 20"

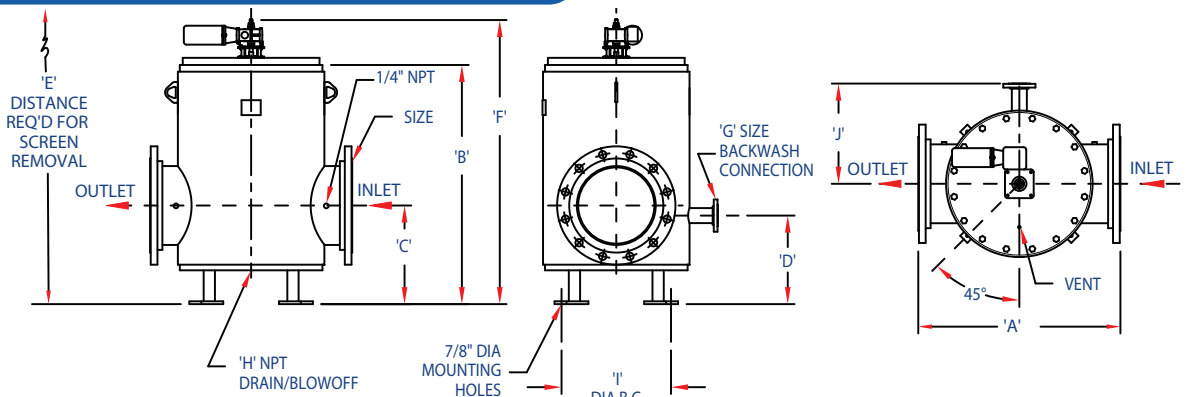

Model No.	Size (in.)	A (in.)	B (in.)	C (in.)	D (in.)	E* (in.)	F* (in.)	G (in.)	H (in.)	I (in.)	J (in.)	Dry Lbs	Wet Lbs	Lbs Cov.	Motor H.P.
100-721T/723T	10-150	28	38 ¹ / ₂	14	11	86	52 ¹ / ₂	2 NPT	1 ¹ / ₂ NPT	18	10 ¹¹ / ₁₆	895	1145	195	1/4
100-721/723	10-150	36	43	17 ¹ / ₂	14 ¹ / ₂	75	55 ¹ / ₂	2 NPT	1 ¹ / ₂ NPT	26	14 ³ / ₄	1595	2245	285	1/4
120-721/723	12-150	36	43	17 ¹ / ₂	14 ¹ / ₂	75	55 ¹ / ₂	2 NPT	1 ¹ / ₂ NPT	26	14 ³ / ₄	1650	2305	285	1/4
140-721/723	14-150	44	51 ¹ / ₂	19 ¹ / ₂	15 ¹ / ₂	94	69	3-150	1 ¹ / ₂ NPT	32	21 ³ / ₄	2525	3800	510	1/4
160-721/723	16-150	44	51 ¹ / ₂	19 ¹ / ₂	15 ¹ / ₂	94	69	3-150	1 ¹ / ₂ NPT	32	21 ³ / ₄	2620	3895	510	1/4
180-721/723	18-150	48	66	24	20 ⁷ / ₈	113	87	3-150	2 NPT	38	25 ¹ / ₄	3225	5470	700	1/4
200-721/723	20-150	48	66	24	20 ⁷ / ₈	113	87	3-150	2 NPT	38	25 ¹ / ₄	3295	5545	700	1/4

(*) Add 4¹/₂" for Model 721. Dimensions subject to change without notice, apply for certified drawings. Weights are approximate.

Series 700 Self-Cleaning Strainers

Specifications Dimensions/Weight

MODEL 721/723 24" - 36"

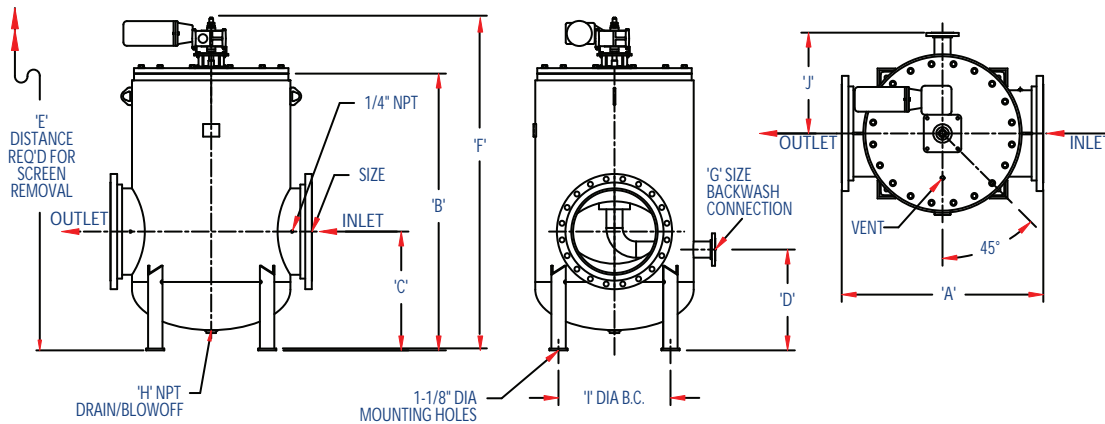

Model No.	Size (in.)	A (in.)	B (in.)	C (in.)	D (in.)	E* (in.)	F* (in.)	G (in.)	H (in.)	I (in.)	J (in.)	Dry Lbs	Wet Lbs	Lbs Cover	Motor H.P.
240-721/723	24-150	56	77	33	28	122	98	4-150	2 NPT	44	28	4500	8475	1000	1/3
300-721/723	30-150	66	94	39	34 1/4	150	115	4-150	2 NPT	54	33	6525	13625	1275	1/3
360-721/723	36-150	86	120	48	40 1/2	210	132	6-150	2 NPT	72	43	12050	26975	1650	1/2

(*) Add 7" for Model 721. Larger sizes available upon request. Dimensions subject to change without notice, apply for certified drawings. Weights are approximate.

SERIES 721/751 SELF-CLEANING STRAINER TYPICAL EXTERNAL SOURCE REQUIREMENT

Strainer Size	1", 1 1/2", 2", or 3"	4"	6"	8"	10/12"	14/16"	18/20"	24"	30"	36"
External Source GPM	10-15	10-15	10-15	10-15	25-35	40-50	50-60	60-70	85-95	115-125
External Line Size	3/4"	3/4"	3/4"	1"	1"	1"	1 1/4"	1 1/2"	1 1/2"	2"
Backwash Linesize	1"	1"	1 1/2"	1 1/2"	2"	3"	3"	4"	4"	6"
Backwash Flow in GPM (Gal. Per Minute)	8-12	15-20	30-40	60-75	110-150	170-210	250-310	400-490	550-700	750-900

TYPICAL BACKWASH FLOW REQUIREMENT

	SERIES 753/793 SELF-CLEANING STRAINER (1" - 8")				SERIES 723/723TSELF-CLEANING STRAINER (10" - 36")					
Strainer Size	1"/1 1/2" 2" or 3"	4"	6"	8"	10/12"	14/16"	18/20"	24"	30"	36"
Backwash Linesize	1"	1"	1 1/2"	1 1/2"	2"	3"	3"	4"	4"	6"
Backwash Flow in GPM (Gal. Per Minute)	8-12	15-20	30-40	60-75	110-150	170-210	250-310	400-490	550-700	750-900

Series 751/753 Cast Self-Cleaning Strainer

ENGINEERED FOR EXCELLENCE

Fluid Engineering had this in mind when we designed our Series 750/753 Cast Self-Cleaning Strainers (Fig. 7). The priority to make quality and economy inherent in the Series 750/753 was Fluid Engineering's obligation to meet our customer's growing needs.



Figure 7

QUALITY

Fluid Engineering Strainers have always been meticulously manufactured with quality in mind. The Fluid Engineering Series 750/753 Cast Self-Cleaning Strainers will continue that important tradition of providing consistent and trouble-free service. They are designed and constructed to be in compliance with ANSI and ASME Section VIII, Division 1.

MODEL 751/753

WATER FLOW G.P.M.

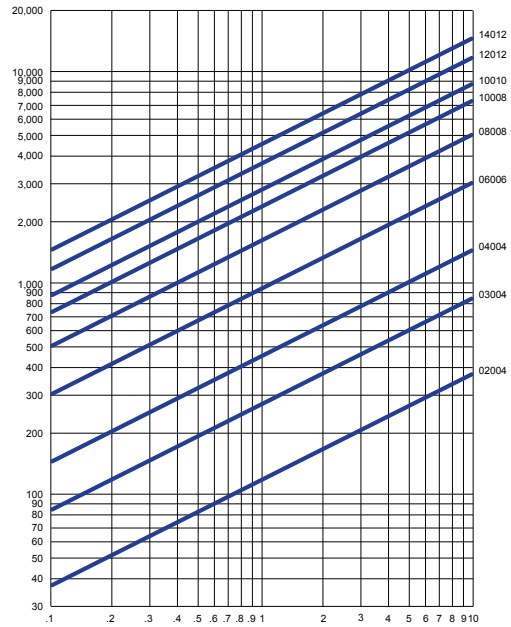

PRESSURE DROP P.S.I. WITH 1/32" OR LARGER SCREEN OPENING

MODEL 751/753 CAST IRON

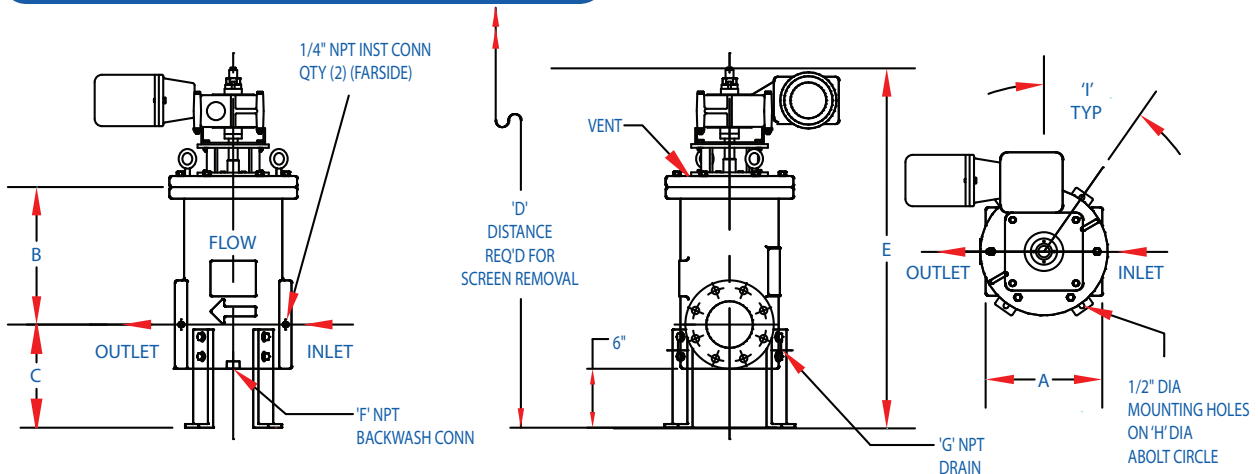

Model No.	Size (in.)	A (in.)	B (in.)	C (in.)	D** (in.)	E** (in.)	F	G	H (in.)	I TYP	Dry Lbs	Wet Lbs	Lbs Cov	Motor H.P.
02004-751/753	2"-125/150FF	23 ⁷ / ₈	14	10 ¹ / ₂	60	37	1" NPT	1" NPT	13 ¹ / ₄	35°	370	520	130	1/4
02504-751/753	2 ¹ / ₂ "-125/150FF	23 ⁷ / ₈	14	10 ¹ / ₂	60	37	1" NPT	1" NPT	13 ¹ / ₄	35°	375	530	130	1/4
03004-751/753	3"-125/150FF	23 ⁷ / ₈	14	10 ¹ / ₂	60	37	1" NPT	1" NPT	13 ¹ / ₄	35°	380	540	130	1/4
04004-751/753	4"-125/150FF	11 ⁷ / ₈	14	10 ¹ / ₂	60	37	1" NPT	1" NPT	13 ¹ / ₄	35°	300	425	130	1/4
06006-751/753	6"-125/150FF	15 ⁷ / ₈	15 ⁷ / ₈	11 ¹ / ₂	62	39	1 ¹ / ₂ " NPT	1" NPT	16 ¹ / ₄	35°	590	690	170	1/4
08008-751/753	8"-125/150FF	32 ⁵ / ₈	20 ³ / ₄	14	75	47 ¹ / ₂	1 ¹ / ₂ " NPT	1" NPT	21 ¹ / ₄	35°	1160	1435	180	1/4
10008-751/753	10"-125/150FF	20 ⁵ / ₈	20 ³ / ₄	14	75	47 ¹ / ₂	1 ¹ / ₂ " NPT	1" NPT	21 ¹ / ₄	35°	875	1120	180	1/4
10010-751/753*	10"-125/150FF	30	27 ¹ / ₂	16 ¹ / ₂	76	56 ¹ / ₂	2" NPT	1" NPT	24 ¹ / ₂	45°	1658	2313	285	1/4
12012-751/753*	12"-125/150FF	30	27 ¹ / ₂	16 ¹ / ₂	76	56 ¹ / ₂	2" NPT	1" NPT	24 ¹ / ₂	45°	1625	2280	285	1/4
14012-751/753*	14"-125/150FF	30	27 ¹ / ₂	16 ¹ / ₂	76	56 ¹ / ₂	2" NPT	1" NPT	24 ¹ / ₂	45°	1600	2255	285	1/4

(*) Bolt holes for footpad on 45° TYP. (**) Add 5¹/₄" for Model 751.

Dimensions subject to change without notice, apply for certified drawings. Weights are approximate.

Series 700 Self-Cleaning Strainers

The Sequence Controller



Figure 8

DESIGN AND CONSTRUCTION

The Fluid Engineering's Sequence Controller is designed with the Customers' specific requirements in mind. The Sequence Controller provides an automatic, effective backwashing cycle with a minimum loss of water.

The Fluid Engineering Sequence Controllers are constructed with state-of-the-art industrial type components, which permits replacing individual components without having to replace an entire circuit board. The industrial type components are more durable and reliable and adjustments can be made with ease (Fig. 8).

MODES OF OPERATION

There are basically two modes of operation – intermittent and continuous. By turning the selector switch, the mode of operation can be selected.

AUTOMATIC INTERMITTENT POSITION

With the selector switch in the "Auto" position, the drive motor will start and the backwash valve opens as determined by the adjustable cycle timer or by the differential pressure switch.

The differential pressure switch is normally factory set at 1 – 1½ psig over the anticipated clean pressure drop. Should a high differential pressure occur during the timed off period, the differential pressure switch will override the cycle timer and start or continue to backwash until the differential pressure is satisfied.

After the differential pressure has been satisfied, the strainer will continue to backwash for an additional 60 seconds (time delay relay).

The Fluid Engineering Automatic Self-Cleaning Strainer would start a backwash cycle based on the timed sequence selected on the adjustable cycle timer. The timed sequence should be determined by each installation and the conditions experienced. The adjustable cycle timer can be programmed from 15 minutes to a 10-hour cycle (off) and for 1 to 15 minutes duration (on). Adjustments can be made as conditions warrant them. The default factory settings for timers are 2 hours OFF and 2 minutes ON.

CONTINUOUS OPERATION

The selector switch is adjusted to "Manual" thus permitting the continuous mode. In the continuous mode, the Fluid Engineering Automatic Self-Cleaning Strainer will be backwashing continuously with the backwash valve open and the drive motor running. This mode of operation may be necessary if the installation experiences high solid loadings.

In either mode of operation, the backwash assembly is specifically designed to rotate at 2 RPM to allow for effective backwashing in less time, thus decreasing the amount of backwash water lost.

CONTROL PACKAGE

The Fluid Engineering Sequence Controller Control Package consists of:

- Control Panel with Nema 4 Enclosure
- Backwash Valve with Electric Operator
- Single Element Differential Pressure Switch

STANDARD FEATURES

- Enclosure – Nema 4
- Adjustable Cycle Timer
- Off-Delay Timer
- Motor Starters with Auxiliary contact and overload relay
- Selector Switch
- Indicating Lights
- Fuses
- Terminal Block

OPTIONS

- 110 V, 230 V, 380 V, 460 V, 575 V
- 50 or 60 hertz
- Dual element differential pressure switch
- Nema 4X (fiberglass or stainless steel), Nema 7 or 9 (explosion proof), Nema 12, Nema 3 enclosures
- Circuit breakers, disconnect switch, transformer
- Reset buttons
- Alarms
- PLC interface and/or pump interlock
- Extra contact and relays

Fluid Engineering

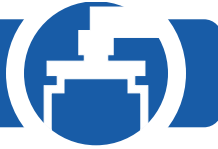

A Division of TM Industrial Supply, Inc. * An Employee-Owned Company

1432 Walnut Street Erie, PA 16502-1746 USA

Phone (814) 453-5014 Fax (814) 452-6573

Email: sales@fluideng.com Web: www.fluideng.com

Various Photos



Typical Piping Layout

721/723 SERIES

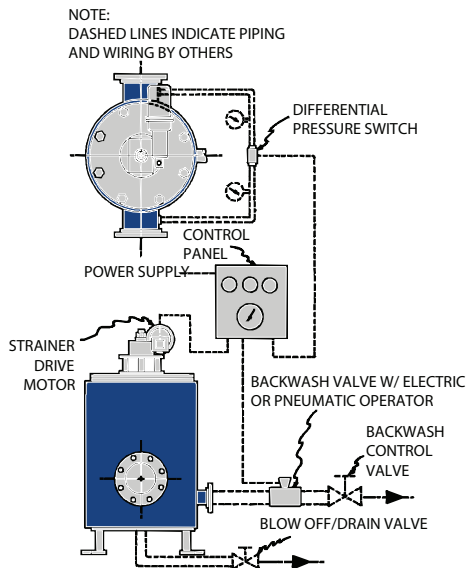

793 SERIES

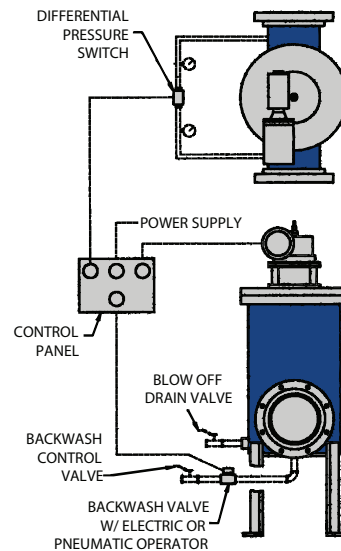

MAY 2011

"Engineered Products for Demanding Applications, Performance, and Service"